

# Ebara Submersible Sewage Pumps (With Cutter)

Model **DF**

## Contents

50Hz

Contents	Pages	Updated
Features and Applications	SDF0073E-K001A	--
Specifications	SDF0073E-K002A	--
Performance Chart & Model Code	SDF0073E-K003A	--
Dimensions – Manual Models – DF	SDF0073E-K004A	--
Dimensions – Automatic Models - DFA	SDF0073E-K005A	--
Dimensions with QDC – 65 & 80 DF	SDF0073E-K006A	--
Dimensions with QDC – 65 & 80 DFA	SDF0073E-K007A	--
Dimensions with QDC – 100 DF	SDF0073E-K008A	--
Dimensions with QDC – 100 DFA	SDF0073E-K009A	--
Performance Curve – 65 DF 51.5	SDF0073E-E001A	--
Performance Curve – 80 DF 51.5	SDF0073E-E002A	--
Performance Curve – 80 DF 52.2	SDF0073E-E003A	--
Performance Curve – 80 DF 53.7	SDF0073E-E004A	--
Performance Curve – 100 DF 53.7	SDF0073E-E005A	--
Performance Curve – 100 DF 55.5	SDF0073E-E006A	--
Sectional View – 65(80) DF 51.5, 80 DF 52.2 & 80(100) DF 53.7	SDF0073E-K010A	--
Sectional View – 100 DF 55.5	SDF0073E-K011A	--
Sectional View – 65(80) DFA 51.5, 80 DFA 52.2 & 80(100) DFA 53.7	SDF0073E-K012A	--

## Features and Applications

50Hz

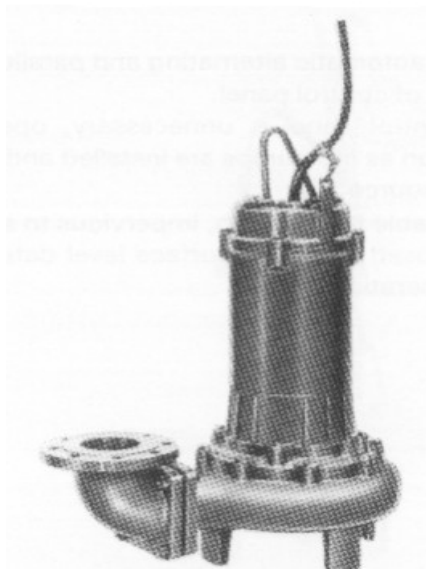

Model DF  
Manual



Model DFA  
Automatic

## Features

### Non-clog operation with “cutting” action

Non-clog semi-open impeller and “cutting” action prevents clogging by fibrous matter. Models up to 3.7 kW have a chrysalis shaped suction port, while larger models have a radially grooved suction cover.

### Robust construction

Rugged cast iron construction, all fasteners of stainless steel and a 4 pole motor.

### Double mechanical seal in oil chamber

An oil lubricated double mechanical seal with lower faces of hard silicon carbide provides strong and reliable shaft sealing

### In built motor protection

Quick acting dual response overloads provides protection against overload, lock or open phase.

### Automatic operation

All models up to 3.7 kW are available as automatic (A' type) pumps with inbuilt controls and float switches. No need for separate control panels, simply connect to power source.

## Applications

Sewage  
Waste water  
Storm water drainage

## Specifications

50Hz

		Standard	Optional
Scope	Discharge	65 – 100 mm	
	Motor Power	1.5 – 5.5 kW (3phase)	
	Performance	Capacity : 0.07 – 2.3 m <sup>3</sup> /min Head : 3 – 18 m.	
Liquid	Type	Sewage	
	Maximum temperature	40° C (Manual and A Type)	
	Max. solids	refer to table below	
Submergence	Maximum	8 m	
	Minimum	Refer to low water level (L.W.L.) in dimensions.	
Construction	Impeller	Non-clog semi-open	
	Mechanical Seal	Oil lubricated, double mechanical seal (single spring up to 3.7 kW) (tandem spring 5.5 kW)	
Materials	Casing	Cast Iron	
	Impeller	Cast Iron	
	Suction Cover	Cast Iron	
	Shaft	403 Stainless Steel	
	Motor Frame	Cast Iron	
	Mechanical Seal	Upper Faces : Carbon / Ceramic Lower Faces : Silicon Carbide / Silicon Carbide Lubricating Oil: Turbine Oil VG32 (SAE10W/20W)	
Motor	Type	Air filled dry submersible, IP68, Class F insulation	
	Speed	4 pole 1500 rpm	
	Applicable Voltages	380/400/415 volts 3 phase 50 Hz	
	Starting	DOL	
	Protection	In built overload protection	
	Bearings	Pre lubricated sealed ball bearings	
Cable	Length	10m	
Accessories	Flange	Discharge elbow with screwed companion flange	
			Quick Discharge Connector (QDC)

Solids Handling			
Model - discharge	65 Ø	80 Ø	100 Ø
- motor kW	All	All	All
Max. Diameter of Solids	40 mm	46 mm	57 mm
Max. Length of Fibers	195 mm	240 mm	300 mm

## Performance Chart

50Hz

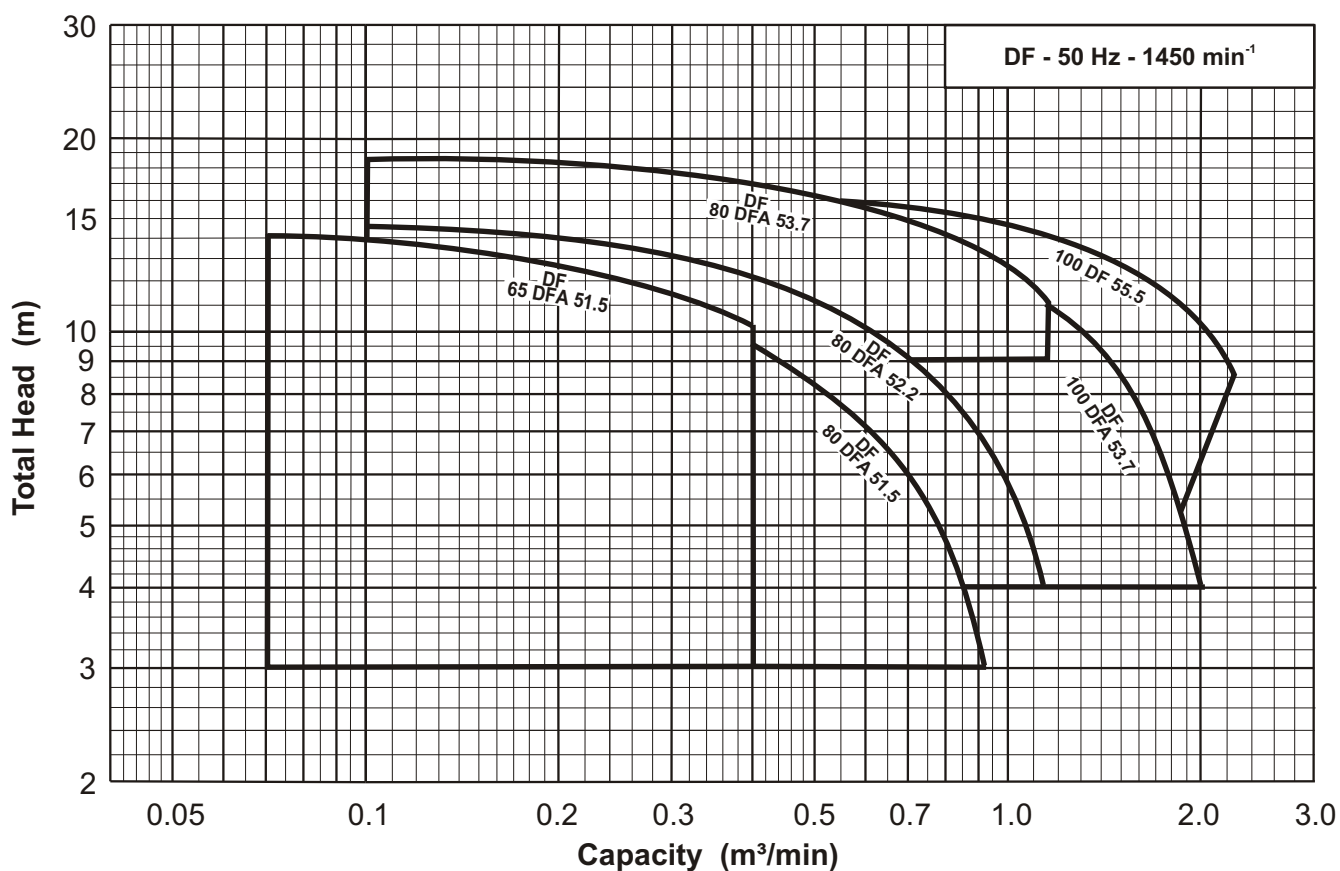

## Model code

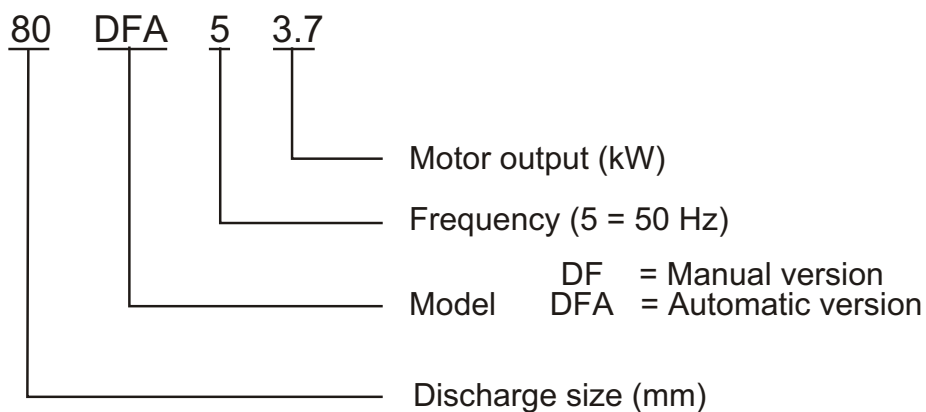

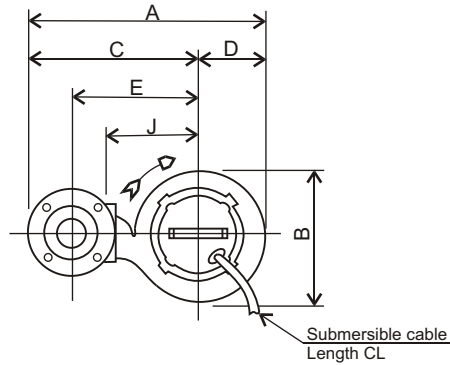

**Discharge Flange Dimensions**  
(JIS 10kgf/cm<sup>2</sup>)

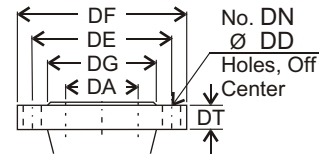

DA	DE	DF	DG	DT	DN	DD
65	150	175	116	18	4	15
80	150	185	126	18	4	15
100	175	210	151	20	8	15

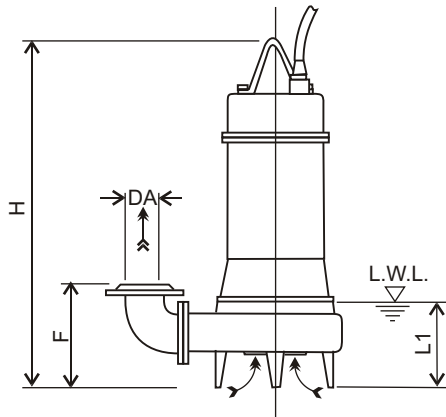

Note:

- 1/. L.W.L. (Low Water Level)  
Is limited to 10 minutes operation at low water level.
- 2/. Is limited to 30 minutes operation with water level below top of motor.

Size DA	Model	Output KW	A	B	C	D	E	F	H	J	L1	CL	Weight
65	65 DF 51.5	1.5	497	291	353	144	265	200	576	200	140	10 m	52 kg
80	80 DF 51.5	1.5	524	292	378	146	285	220	597	210	165	10 m	55 kg
	80 DF 52.2	2.2	542	308	388	154	295	220	654	220	165	10 m	67 kg
	80 DF 53.7	3.7	567	328	403	164	310	220	687	235	165	10 m	75 kg
100	100 DF 53.7	3.7	614	335	445	169	340	250	706	235	185	10 m	79 kg
	100 DF 55.5	5.5	646	369	460	186	355	323	768	250	205	10 m	123 kg

Units: mm unless otherwise specified

## Dimensions - Automatic Models - DFA

50Hz

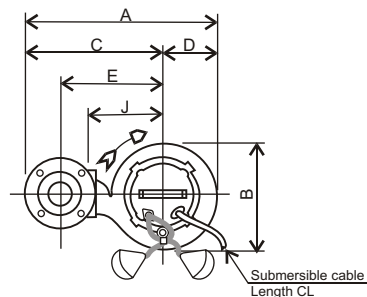
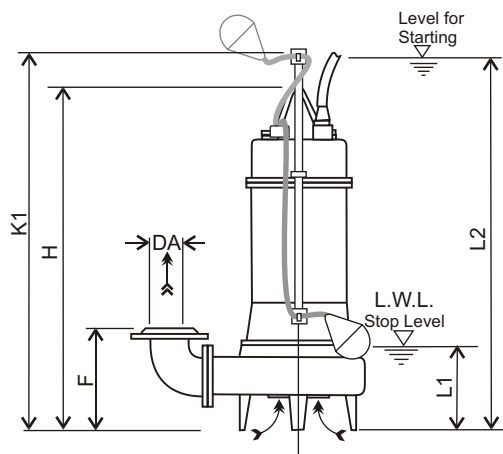

- Note:
- 1/. L.W.L (Low Water Level) Is limited to 10 minutes operation at low water level.
  - 2/. Is limited to 30 minutes operation with water level below top of motor.

### Discharge Flange Dimensions (JIS 10kgf/cm<sup>2</sup>)

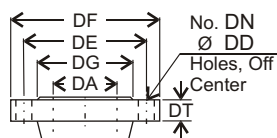

DA	DE	DF	DG	DT	DN	DD
65	150	175	116	18	4	15
80	150	185	126	18	8	15
100	175	210	151	20	8	15

Size DA	Model	Output KW	A	B	C	D	E	F	H	J	K1	L1	L2	CL	Weight
65	65 DFA 51.5	1.5	497	291	353	144	265	200	662	200	840	320	860	10 m	55 kg
80	80 DFA 51.5	1.5	524	292	378	146	285	220	683	210	840	320	860	10 m	58 kg
	80 DFA 52.2	2.2	542	308	388	154	295	220	728	220	840	320	860	10 m	70 kg
	80 DFA 53.7	3.7	567	328	403	164	310	220	761	235	840	320	860	10 m	78 kg
100	100 DFA 53.7	3.7	614	335	445	169	340	250	780	235	840	320	860	10 m	85 kg

Units: mm unless otherwise specified

# Ebara Submersible Sewage Pumps (With Cutter)

Model **DF**

## Dimensions with QDC

Pump **DF** QDC **LM**

### Applicable Models - 65 & 80 DF

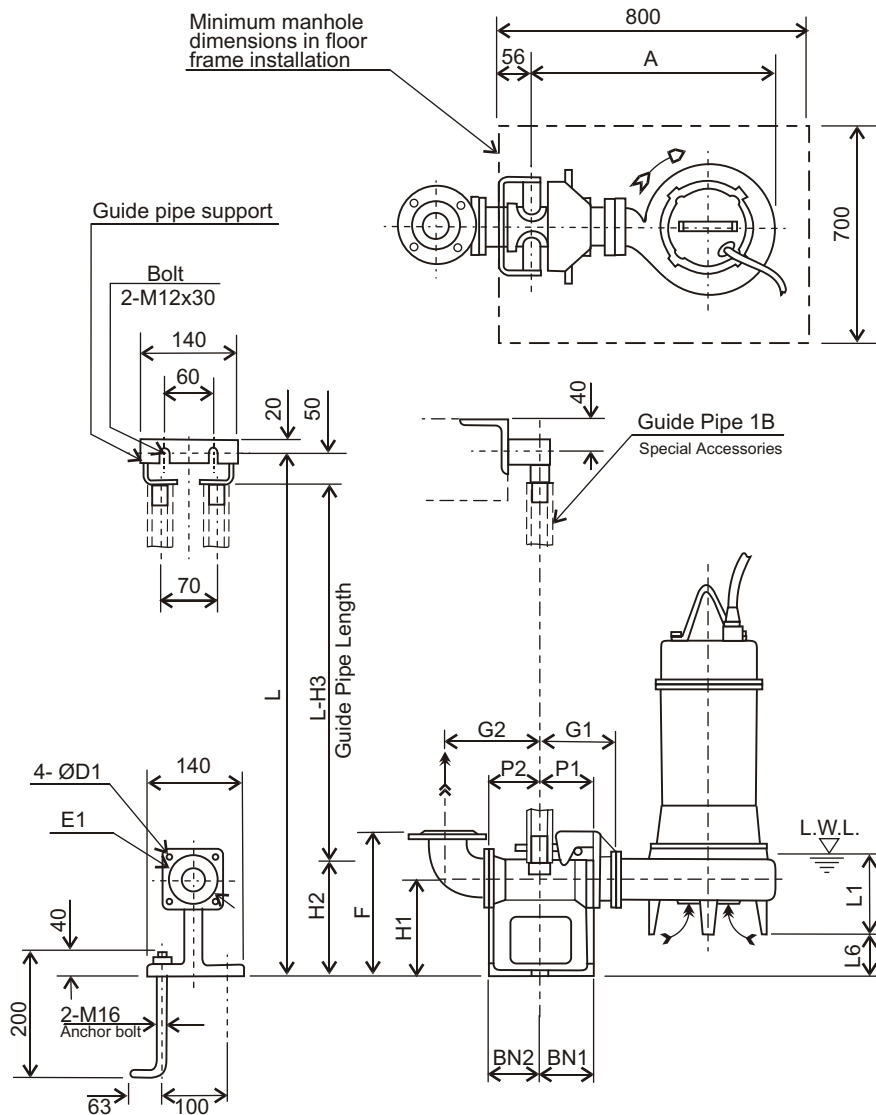

Note:

1/. For detailed dimensions of the pumps, refer to separate dimension data sheets.

2/. The discharge bend and companion flange supplied with the pump are used with the QDC.

3/. The weight in dimension tables refers only to the weight of the QDC.

4/. Standard accessories supplied with QDC include:-

- Connector body with foundation bolts.
- Guide pipe support
- Sliding Glide
- Adaptor Flange

Guide Pipe is not supplied.

Discharge Flange  
(JIS 10kgf/cm<sup>2</sup>)

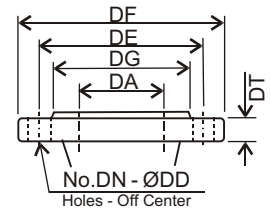

DA	DE	DF	DG	DT	DN	DD
65	140	175	116	18	4	15
80	150	185	126	18	8	15

Pump Model	A	P1	P2	G1	G2	F	H1	H2	H3	L1	L6	BN1	BN2	D1	E1	QDC Model	Weight
65 DF 51.5	464	75	95	120	160	250	145	190	240	140	50	75	95	12	140	LM65	14 kg
80 DF 51.5	481	75	90	125	165	285	175	230	280	165	65	75	90	15	155	LM80	17 kg
80 DF 52.2	499	75	90	125	165	285	175	230	280	165	65	75	90	15	155	LM80	17 kg
80 DF 53.7	524	75	90	125	165	285	175	230	280	165	65	75	90	15	155	LM80	17 kg

Units: mm unless otherwise specified

### Applicable Models - 65 & 80 DFA

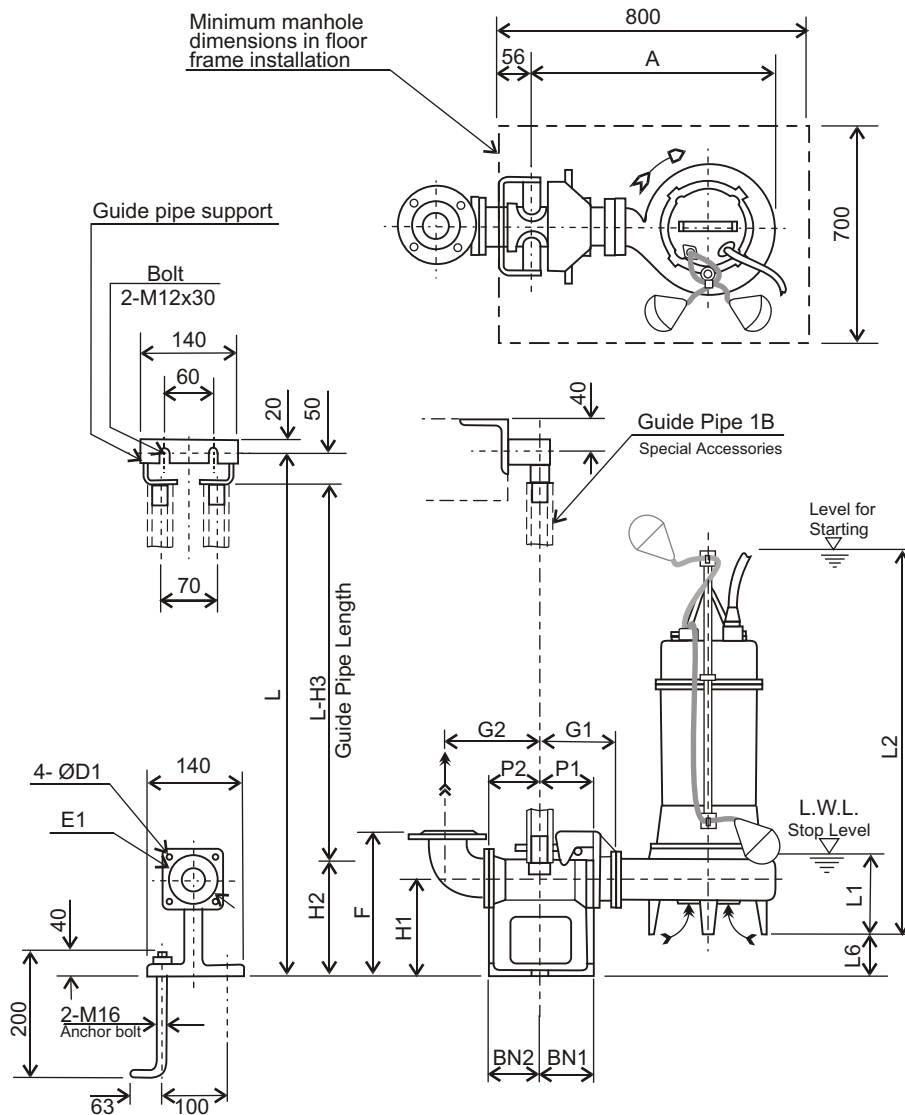

Note:

1/ For detailed dimensions of the pumps, refer to separate dimension data sheets.

2/ The discharge bend and companion flange supplied with the pump are used with the QDC.

3/ The weight in dimension tables refers only to the weight of the QDC.

4/ Standard accessories supplied with QDC include:-

- Connector body with foundation bolts.
- Guide pipe support
- Sliding Glide
- Adaptor Flange

Guide Pipe is not supplied.

**Discharge Flange**  
(JIS 10kgf/cm<sup>2</sup>)

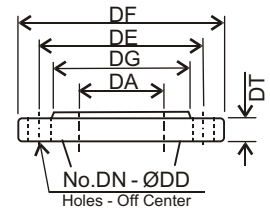

DA	DE	DF	DG	DT	DN	DD
65	140	175	116	18	4	15
80	150	185	126	18	8	15

Pump Model	A	P1	P2	G1	G2	F	H1	H2	H3	L1	L2	L6	BN1	BN2	D1	E1	QDC Model	Weight
65 DFA 51.5	464	75	95	120	160	250	145	190	240	320	860	50	75	95	12	140	LM65	14 kg
80 DFA 51.5	481	75	90	125	165	285	175	230	280	320	860	65	75	90	15	155	LM80	17 kg
80 DFA 52.2	499	75	90	125	165	285	175	230	280	320	860	65	75	90	15	155	LM80	17 kg
80 DFA 53.7	524	75	90	125	165	285	175	230	280	320	860	65	75	90	15	155	LM80	17 kg

Units: mm unless otherwise specified



### Applicable Models - 100 DF

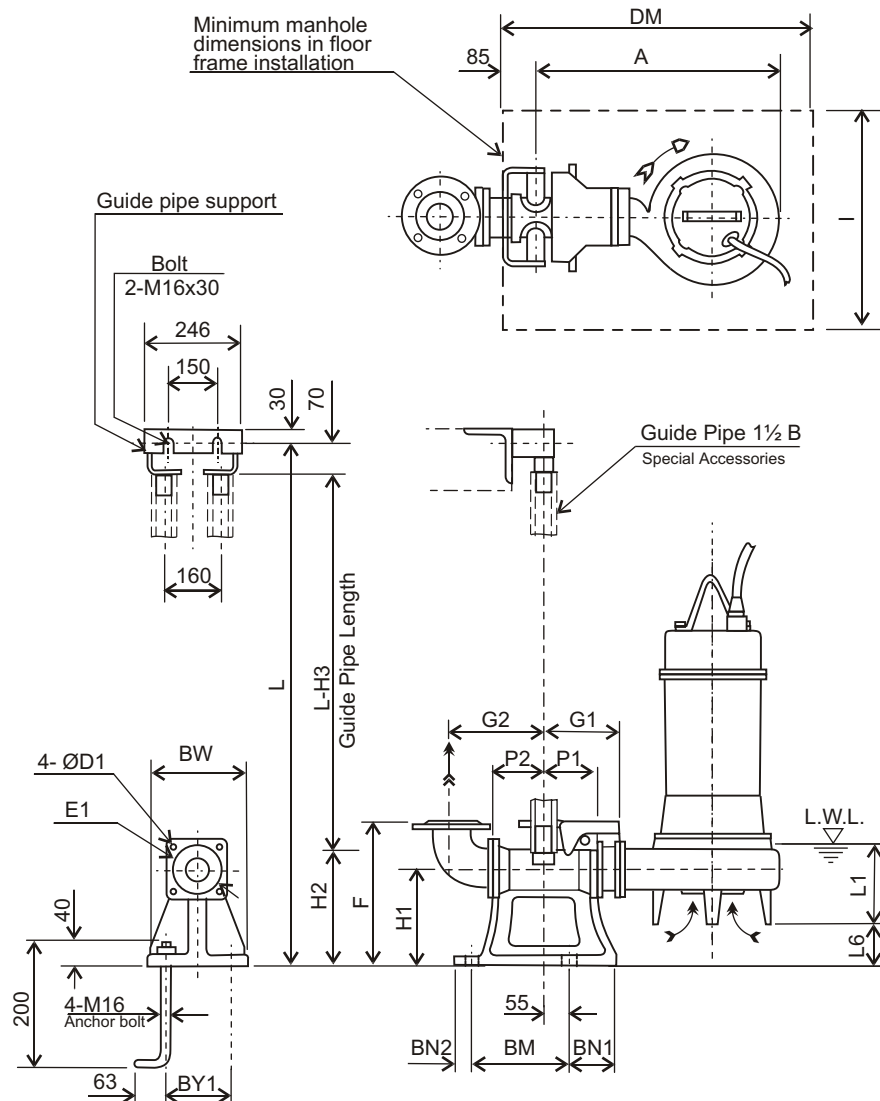

Note:

1/ For detailed dimensions of the pumps, refer to separate dimension data sheets.

2/ The discharge bend and companion flange supplied with the pump are used with the QDC.

3/ The weight in dimension tables refers only to the weight of the QDC.

4/ Standard accessories supplied with QDC include:-

- Connector body with foundation bolts.
- Guide pipe support
- Sliding Glide
- Adaptor Flange

Guide Pipe is not supplied.

Discharge Flange  
(JIS 10kgf/cm<sup>2</sup>)

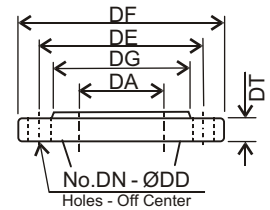

DA	DE	DF	DG	DT	DN	DD
100	175	210	151	20	8	15

Pump Model	A	P1	P2	G1	G2	F	H1	H2	H3	L1	L6	BN1	BN2	BM	BY1	BW	DM	I	D1	E1	QDC Model	Weight
100 DF 53.7	589	105	105	185	210	365	240	265	335	185	115	100	40	220	180	230	800	700	19	175	LL100	46 kg
100 DF 55.5	621	105	105	185	210	365	240	265	335	205	42	100	40	220	180	230	800	700	19	175	LL100	46 kg
100 DF 57.5	648	105	105	185	210	365	240	265	335	205	42	100	40	220	180	230	800	700	19	175	LL100	46 kg

Units: mm unless otherwise specified

### Applicable Models - 100 DFA

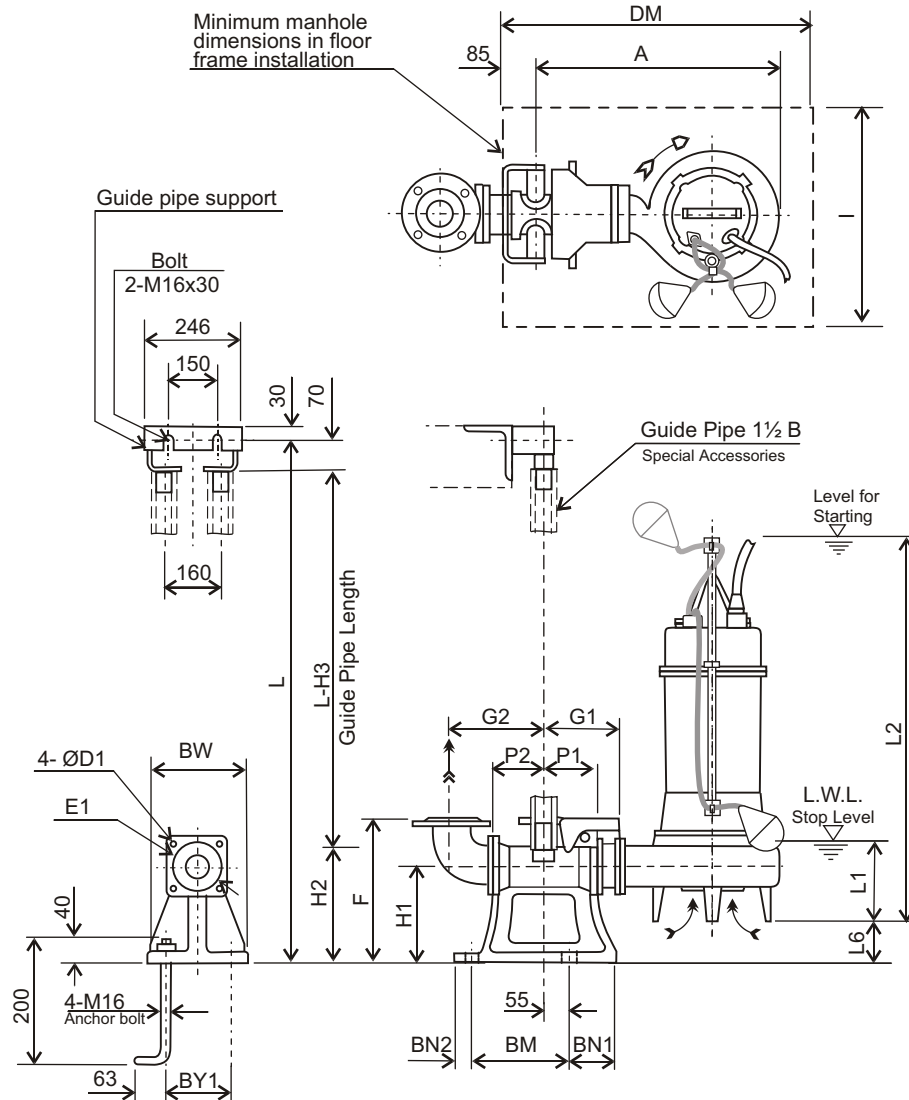

Note:

1/. For detailed dimensions of the pumps, refer to separate dimension data sheets.

2/. The discharge bend and companion flange supplied with the pump are used with the QDC.

3/. The weight in dimension tables refers only to the weight of the QDC.

4/. Standard accessories supplied with QDC include:-

- Connector body with foundation bolts.
- Guide pipe support
- Sliding Glide
- Adaptor Flange

Guide Pipe is not supplied.

**Discharge Flange**  
(JIS 10kgf/cm<sup>2</sup>)

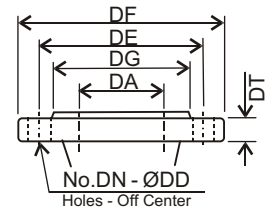

DA	DE	DF	DG	DT	DN	DD
100	175	210	151	20	8	15

Pump Model	A	P1	P2	G1	G2	F	H1	H2	H3	L1	L2	L6	BN1	BN2	BM	BY1	BW	DM	I	D1	E1	QDC Model	Weight	
100 DFA	53.7	589	105	105	185	210	365	240	265	335	320	860	115	100	40	220	180	230	800	700	19	175	LL100	46 kg

Units: mm unless otherwise specified

## Sectional View - 65(80) DF 51.5, 80 DF 52.2 & 80(100) DF 53.7 50Hz

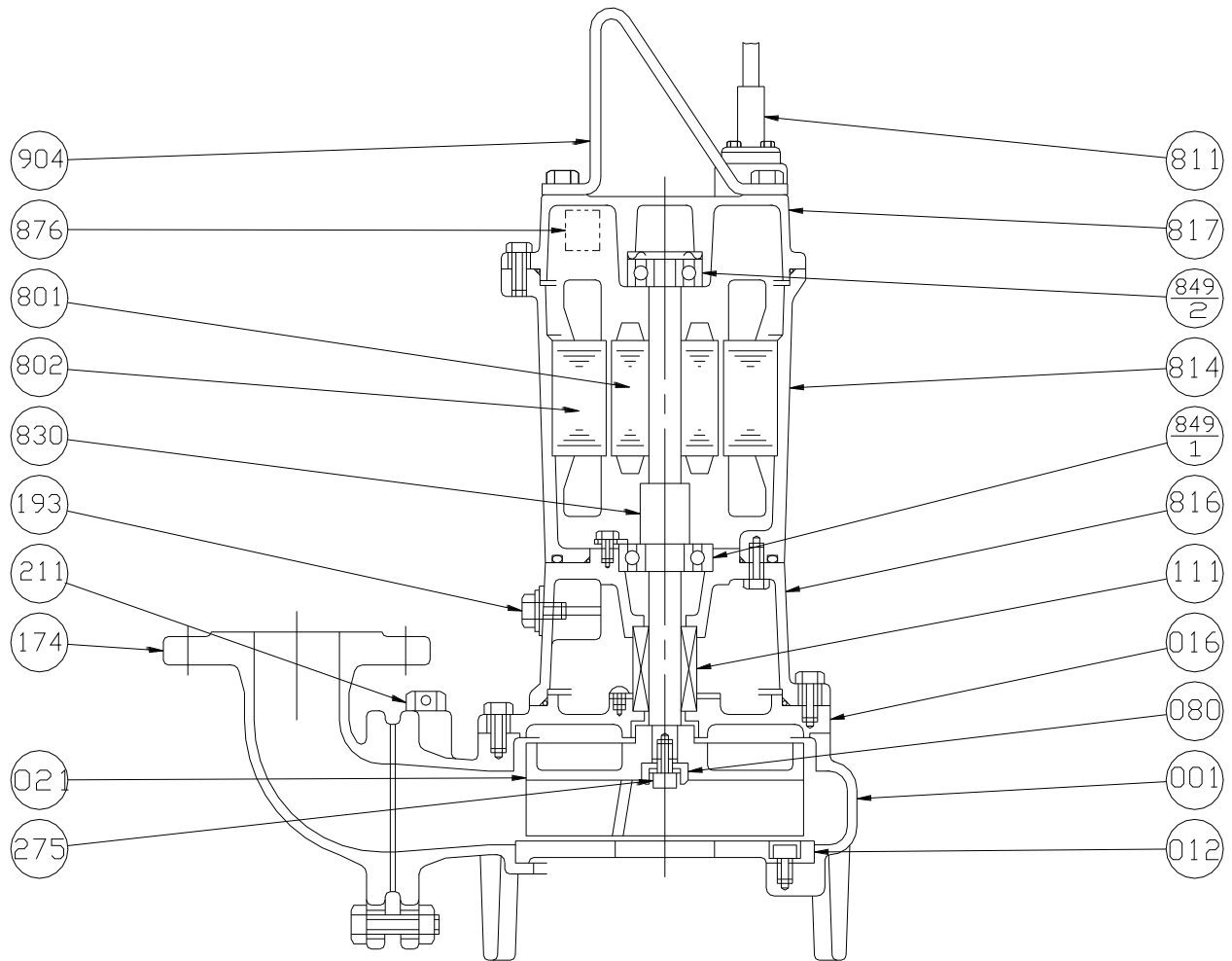

Item Number	Description	Material	Quantity per unit
001	Pump Casing	FC200 Cast iron	1
012	Suction Cover	FC200 Cast Iron	1
016	Mechanical Seal Cover	FC200 Cast iron	1
021	Impeller	FC200 Cast iron	1
080	Bushing	SS Steel	1
111	Mechanical Seal		1
174	Discharge Bend	FC200 Cast iron	1
193	Oil Plug	C3604 or SUS304 Brass or 304 Stainless Steel	1
211	Airvent Valve	C3604 Brass	1
275	Impeller Bolt	SUS304 Stainless Steel	1

Item Number	Description	Material	Quantity per unit
801	Rotor		1
802	Stator		1
811	Submersible Cable		1
814	Motor Frame	FC150 Cast Iron	1
816	Power Side Bracket	FC150 Cast Iron	1
817	Opposite Side Bracket	FC150 Cast Iron	1
830	Shaft	SUS403 Stainless Steel	1
849-1	Ball Bearing		1
849-2	Ball Bearing		1
876	Protector		1
904	Lifting Hanger	SS Steel	1

## Sectional View - 100 DF 55.5

50Hz

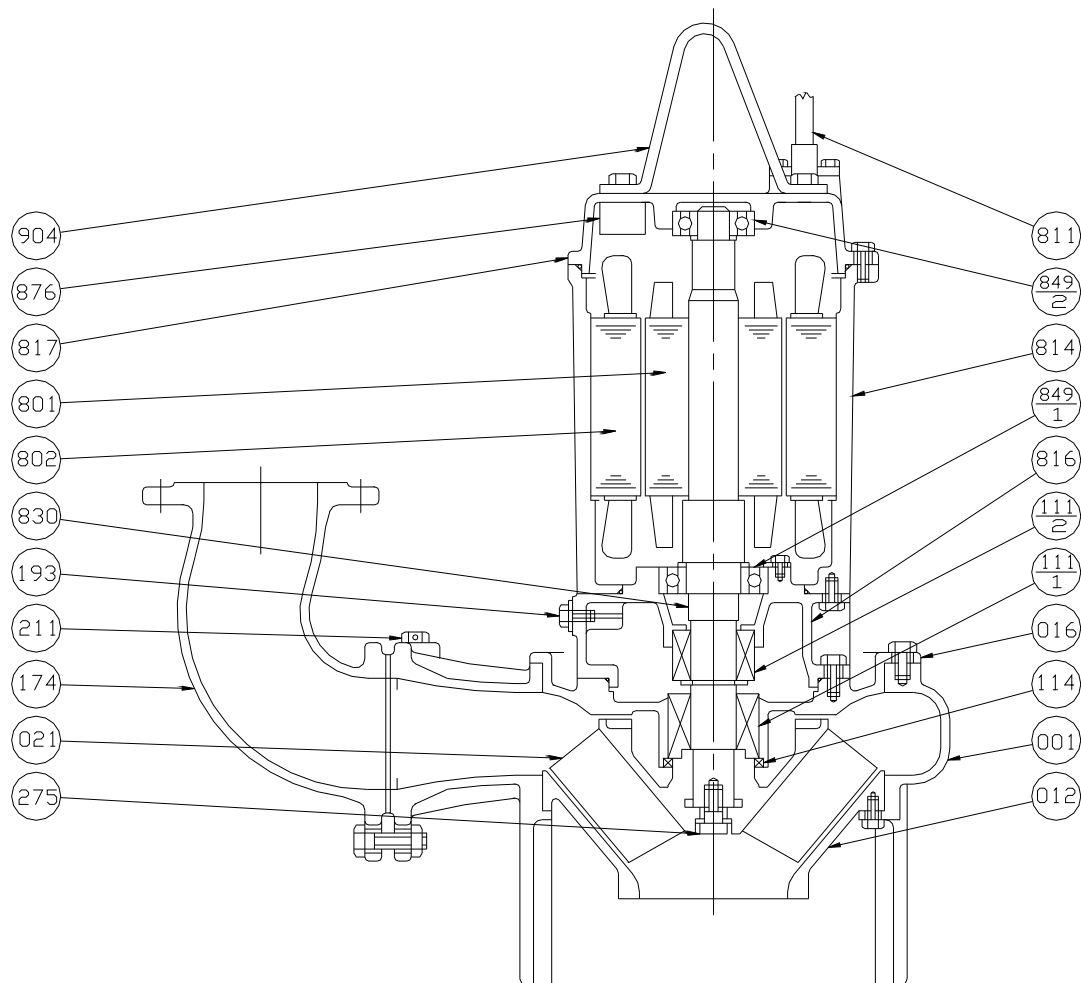

Item Number	Description	Material	Quantity per unit
001	Pump Casing	FC200 Cast iron	1
012	Suction Cover	FC200 Cast Iron	1
016	Mechanical Seal Cover	FC200 Cast iron	1
021	Impeller	FC200 Cast iron	1
111-1	Mechanical Seal		1
111-2	Mechanical Seal		1
114	Oil Seal	NBR Rubber	1
174	Discharge Bend	FC200 Cast iron	1
193	Oil Plug	C3604 or SUS304 Brass or 304 Stainless Steel	1
211	Airvent Valve	C3604 Brass	1
275	Impeller Bolt	SUS304 Stainless Steel	1

Item Number	Description	Material	Quantity per unit
801	Rotor		1
802	Stator		1
811	Submersible Cable		1
814	Motor Frame	FC150 Cast Iron	1
816	Power Side Bracket	FC150 Cast Iron	1
817	Opposite Side Bracket	FC150 Cast Iron	1
830	Shaft	SUS403 Stainless Steel	1
849-1	Ball Bearing		1
849-2	Ball Bearing		1
876	Protector		1
904	Lifting Hanger	SS Steel	1

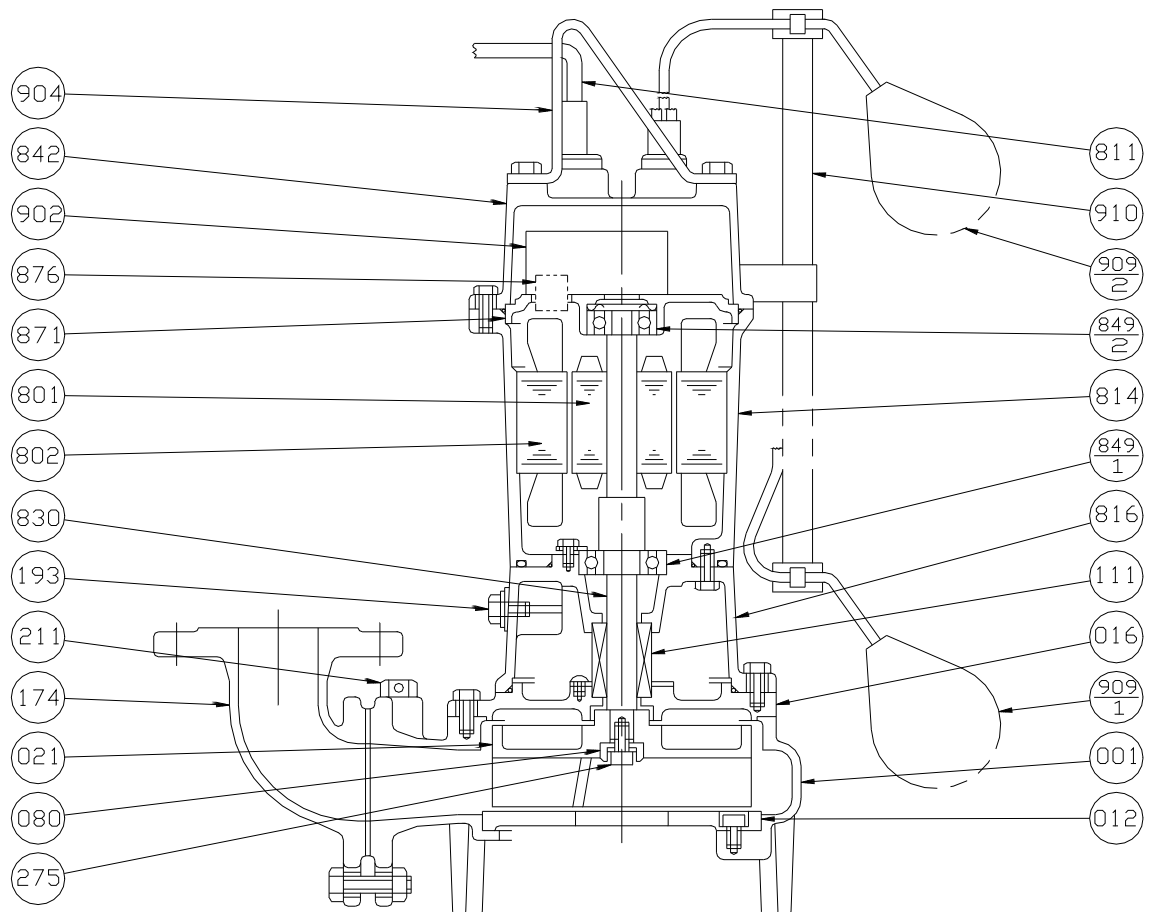

Item Number	Description	Material	Quantity per unit
001	Pump Casing	FC200 Cast iron	1
012	Suction Cover	FC200 Cast Iron	1
016	Mechanical Seal Cover	FC200 Cast iron	1
021	Impeller	FC200 Cast iron	1
080	Bushing	SS Steel	1
111	Mechanical Seal		1
174	Discharge Bend	FC200 Cast iron	1
193	Oil Plug	C3604 or SUS304 Brass or Stainless Steel	1
211	Airvent Valve	C3604 Brass	1
275	Impeller Bolt	SUS304 Stainless Steel	1
801	Rotor		1
802	Stator		1
811	Submersible Cable		1

Item Number	Description	Material	Quantity per unit
814	Motor Frame	FC150 Cast Iron	1
816	Power Side Bracket	FC150 Cast Iron	1
830	Shaft	SUS403 Stainless Steel	1
842	Motor Cover	FC150 Cast Iron	1
849-1	Ball Bearing		1
849-2	Ball Bearing		1
871	Intermediate Bracket	FC150 Cast Iron	1
876	Protector		1
902	Control Device		1
904	Lifting Hanger	SS Steel	1
909-1	Float Switch		1
909-2	Float Switch		1
910	Float Pole	Plastics	1