

Twin impeller centrifugal pumps manufactured from stainless steel AISI 304, suitable for water supply, treatment and irrigation. Air conditioning systems and general water pumping including moderately aggressive liquids



SPECIFICATIONS

- Maximum working pressure: 8 bar
- Maximum liquid temperature: 35°C according EN 60335-2-41 for domestic uses 60°C for other uses

MATERIALS

- Pump body, impeller, diffuser, casing cover, bracket, shaft, motor casing and fan cover in AISI 304
- Mechanical seal in carbon/ceramic/NBR
- Special mechanical seal are available on demand

TECHNICAL DATA

- T.E.F.C. 2 poles motor
- Insulation class F
- Protection degree IP55
- 1~230V ± 10% 50Hz, 3~230/400V ± 10% 50Hz
- Permanent split capacitor and automatic thermal overload protection for single-phase version
- Thermal protection to be provided by the user for three-phase version
- DNM 1" - DNA 1 1/4"

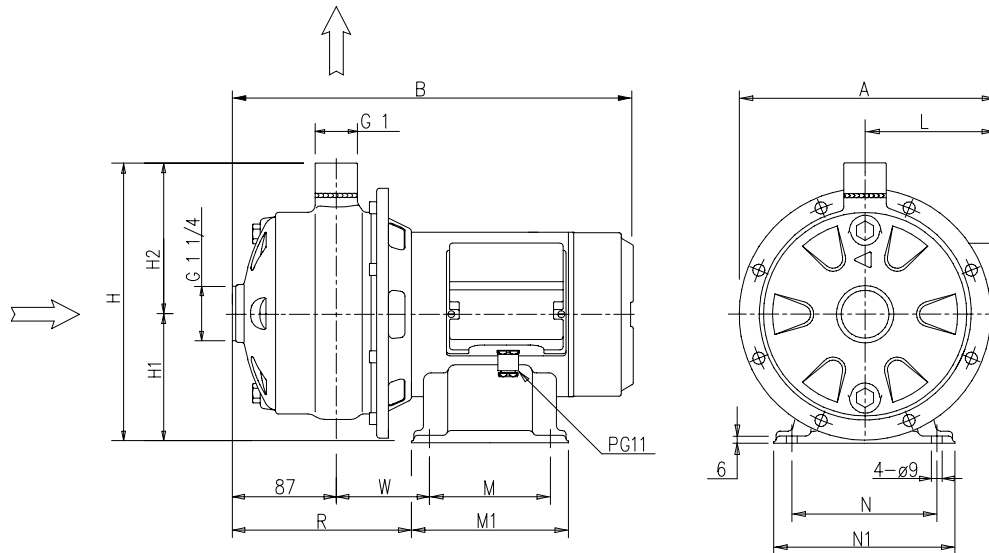

DIMENSIONAL TABLE

Pump type		Dimensions (mm)														Weight		
		A		B		H	H1	H2	L		M	M1	N	N1	R	W	kg	
Single-phase	Three-phase	1~	3~	1~	3~				1~	3~							1~	3~
2CDM 70/10	2CD 70/10	210	206	363	363	229	106	123	106	102	100	130	120	150	164	93	14	14
2CDM 70/12	2CD 70/12	206	206	363	363	229	106	123	102	102	100	130	120	150	164	93	14,7	14,7
2CDM 70/15	2CD 70/15	226	226	375	393	229	106	123	110	110	120	150	140	170	170	95	17,8	17,8
2CDM 70/20	2CD 70/20	214	214	393	393	229	106	123	110	110	120	150	140	170	170	95	19,8	18,8
2CDM 120/15	2CD 120/15	214	214	375	393	229	106	123	110	110	120	150	140	170	170	95	16,1	15,8
2CDM 120/20	2CD 120/20	214	214	393	393	229	106	123	110	110	120	150	140	170	176	95	17,8	17,5

PERFORMANCE CHART (according to ISO 9906 Annex A)

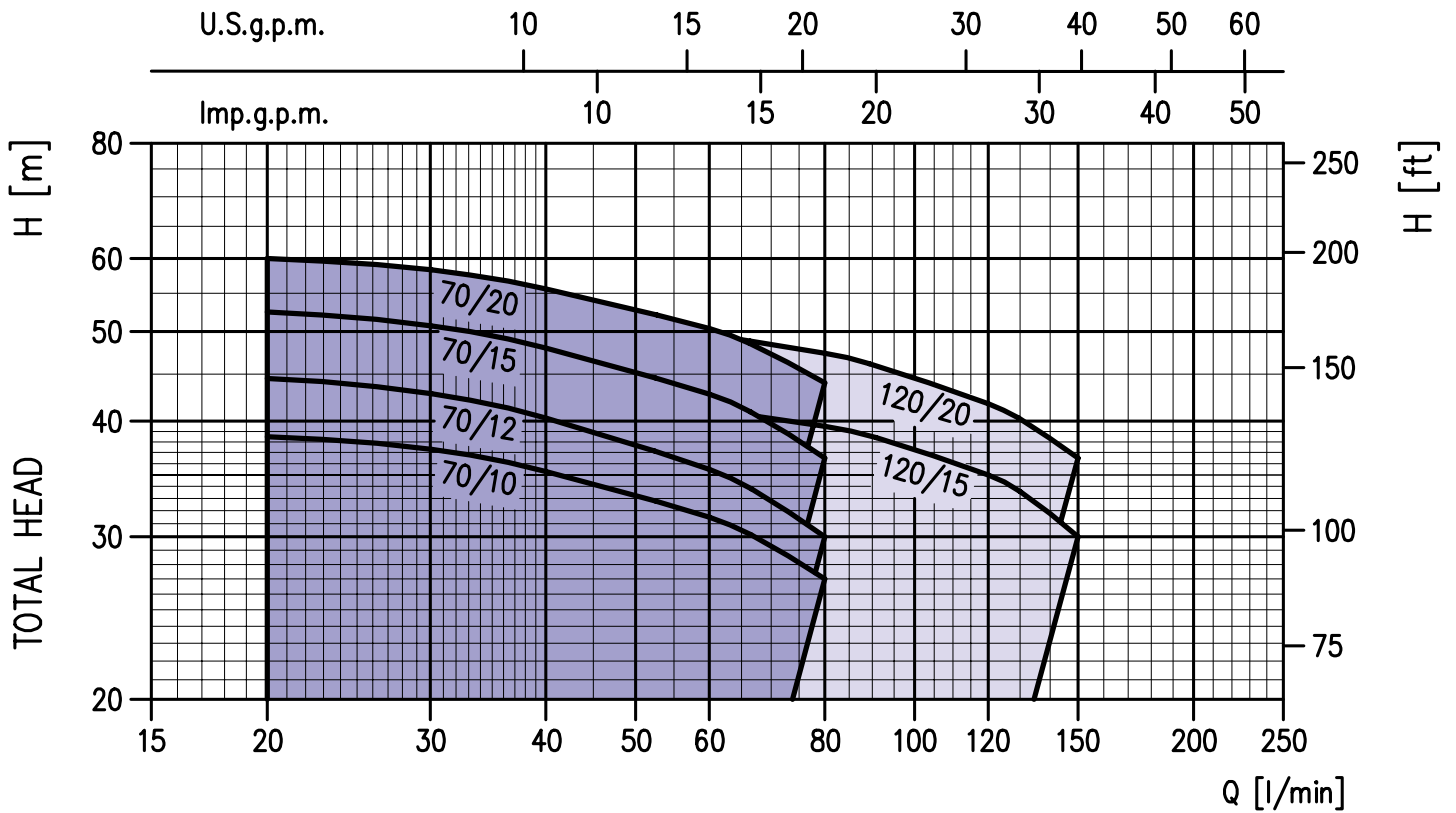

PERFORMANCE TABLE

Pump type		kW	Capacitor		Absorbed Current (A)			l/min m ³ /h	Q=Capacity					
Single-phase 230V 50Hz	Three-phase 230/400V 50Hz		μF	V _c	Single-phase	three-phase 230V 400V			20	40	60	80	120	150
2CDM 70/10	2CD 70/10	0,75	20	450	5,8	4,0	2,3	1,2	2,4	3,6	4,8	7,2	9	
2CDM 70/12	2CD 70/12	0,9	31,5	450	7,0	5,0	2,9	38,5	35,3	31,5	27	-	-	
2CDM 70/15	2CD 70/15	1,1	35	450	8,1	5,6	3,3	44,5	40,3	35,5	30	-	-	
2CDM 70/20	2CD 70/20	1,5	40	450	10,0	7,0	4,0	52,5	48	42,8	36,5	-	-	
2CDM 120/15	2CD 120/15	1,1	35	450	8,3	5,6	3,3	60	55,6	50,4	44	-	-	
2CDM 120/20	2CD 120/20	1,5	40	450	10,2	7,0	4,0	-	42	41	39,5	35	30	
								-	51,5	49,5	47,4	41,8	36,5	

PERFORMANCE CURVES 2CD 70 series (according to ISO 9906 Annex A)

