

Self-priming jet pumps produced in cast iron, suitable for water supply, domestic pressure boosting and small irrigation systems, pool and tank emptying and general clean water pumping.



SPECIFICATIONS

- Maximum working pressure: 6 bar
- Maximum liquid temperature: 35°C according EN 60335-2-41 for domestic uses 45°C for other uses
- Maximum suction: 8 mts

MATERIALS

- Pump body in cast iron
- Casing cover in AISI 304
- Shaft in AISI 416
- Impeller, nozzle and diffuser in tecnopolymer
- Mechanical seal in carbon/ceramic/NBR

TECHNICAL DATA

- Asynchronous 2 poles motor
- Insulation class F
- Protection degree IP44
- 1~230V ± 10% 50Hz, 3~230/400V ± 10% 50Hz
- Permanent split capacitor and automatic thermal overload protection for single-phase version
- Thermal protection to be provided by the user for three-phase version
- DNA-DNM 1"

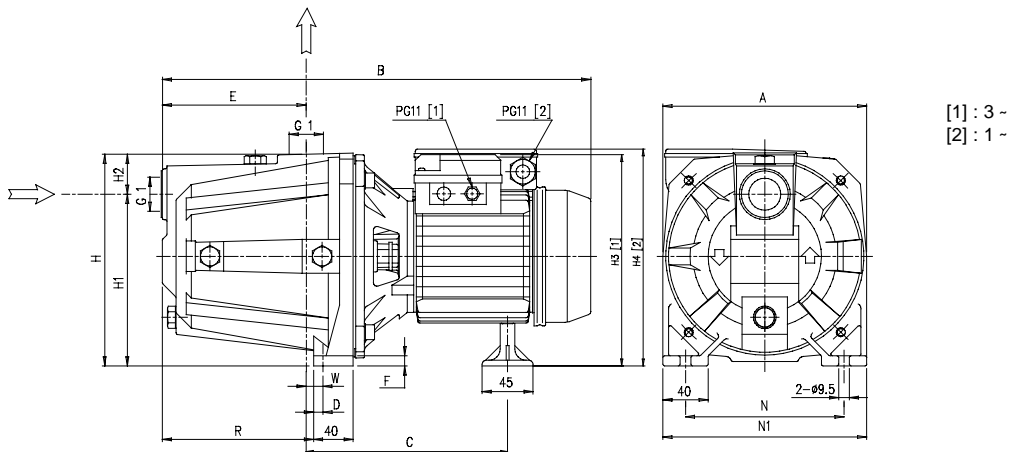

DIMENSIONAL TABLE

Pump type		Dimensions (mm)														Weight kg	
		A	B	C	D	E	F	H	H1	H2	H3	H4	N	N1	R		W
Single-phase	Three-phase										3~	1~					
AGE 0.50 M	AGE 0.50 T	150	352	193	17,3	99,5	8	160	122	38	172,5	174	110	150	111	24	8
AGE 0.60 M	AGE 0.60 T	150	352	193	17,3	99,5	8	160	122	38	172,5	174	110	150	111	24	8,5
AGE 0.80 M	AGE 0.80 T	150	352	193	17,3	99,5	8	160	122	38	172,5	174	110	150	111	24	9
AGF 0.60 M	AGF 0.60 T	180	377	191	10,3	127	9	185	152	33	187,5	189	140	180	129	12	11
AGF 0.80 M	AGF 0.80 T	180	377	191	10,3	127	9	185	152	33	187,5	189	140	180	129	12	12

PERFORMANCE CURVES (according to ISO 9906 Annex A)

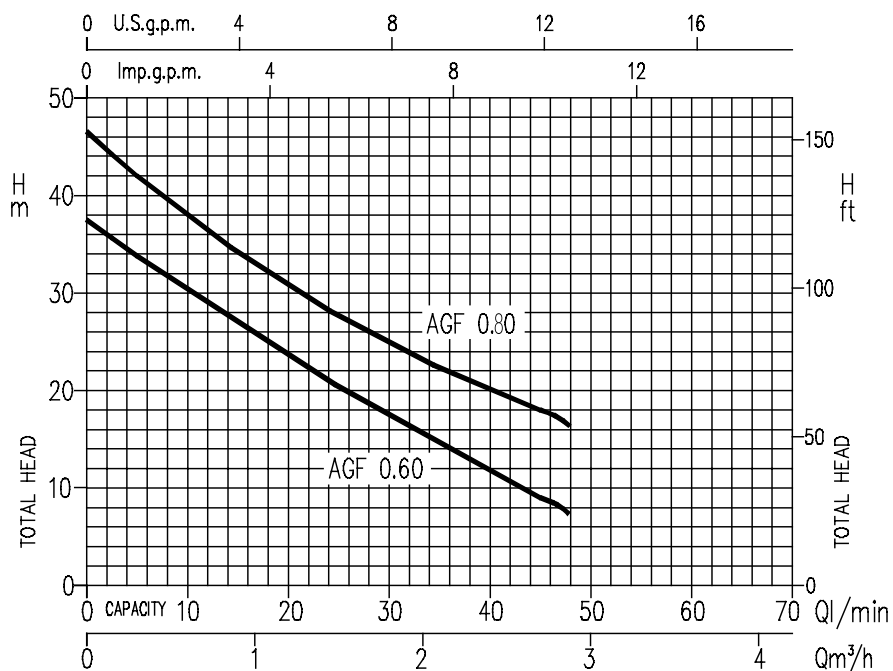
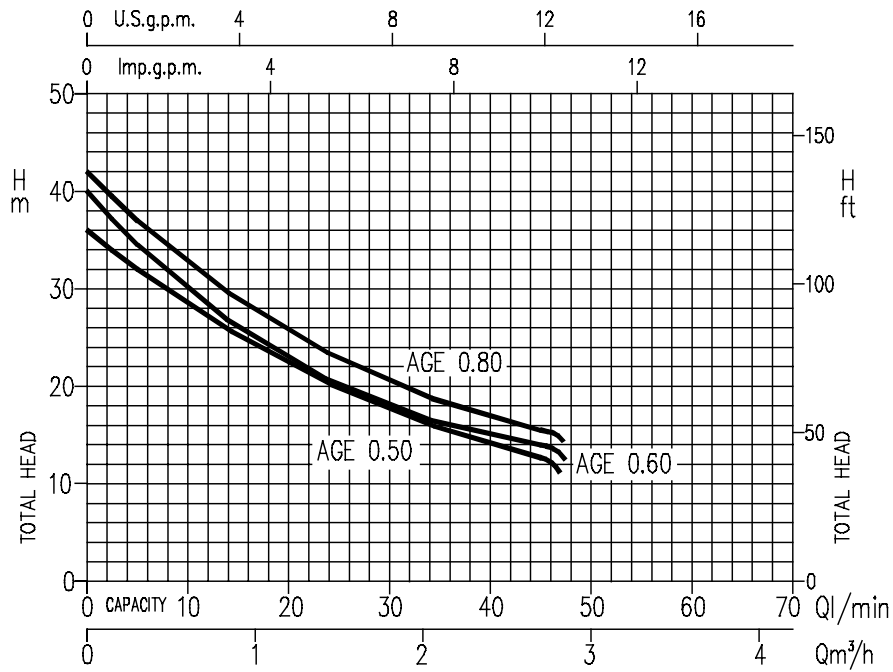

PERFORMANCE TABLE

Pump type		kW	Capacitor		Absorbed Current (A)			l/min m³/h	Q=Capacity					
Single-phase 230V 50Hz	Three-phase 230/400V 50Hz		μF	V _c	1~	230V 3~	400V 3~		5	10	20	30	40	45
								H=Total head						
AGE 0.50 M	AGE 0.50 T	0,37	10	450	2,4	2	1,1	32	28,4	22,4	17,6	14,1	12,7	
AGE 0.60 M	AGE 0.60 T	0,45	10	450	2,75	2	1,1	34,5	29,9	22,8	17,9	14,9	14	
AGE 0.80 M	AGE 0.80 T	0,6	10	450	2,8	2,1	1,2	37	32,7	25,6	20,5	16,8	15,5	
AGF 0.60 M	AGF 0.60 T	0,45	10	450	3	2,1	1,2	33,8	30,2	23,5	17,3	11,7	9	
AGF 0.80 M	AGF 0.80 T	0,6	12,5	450	3,7	2,4	1,4	42	37,9	30,7	24,8	20	18	